

ENHANCING CAR RIDE COMFORT USING A BALANCED CONTROLLER DESIGN FOR SEMI-ACTIVE SUSPENSION SYSTEM

Vu Van Tan

University of Transport and Communications - Hanoi - Vietnam

ABSTRACT

Automobile ride comfort quality is an important factor in car design. There are some approaches that can be used to improve this characteristic, in which the researchers in Vietnam and in the world are interested in the semi-active suspension system. This paper presents a balance control method applied to the semi-active suspension system with two control strategies including on-off and continuous balance controllers. The main idea of this method is that the force of the controlled damping will change, so that the magnitude of the force is equal to that of the spring, but the direction of the forces is the opposite. This will reduce the vertical acceleration of the vehicle body. The simulation results in the time domain have been clearly shown by using the balance control methods. The root mean square of the vertical displacement, pitch angle and their accelerations decrease by 25-50%, compared to the passive suspension system.

Keywords: *Vehicle dynamics; Balance control; Ride comfort; Suspension system; Semi-active control.*

Received: 14/11/2019; Revised: 22/02/2020; Published: 26/02/2020

THIẾT KẾ BỘ ĐIỀU KHIỂN CÂN BẰNG CHO HỆ THỐNG TREO BÁN TÍCH CỰC ĐỂ NÂNG CAO ĐỘ ÊM DỊU CỦA Ô TÔ

Vũ Văn Tấn

Trường Đại học Giao thông Vận tải - Hà Nội - Việt Nam

TÓM TẮT

Độ êm dịu chuyển động là một yếu tố quan trọng trong việc thiết kế ô tô. Có nhiều cách tiếp cận có thể được sử dụng để nâng cao đặc tính này, trong đó các nhà nghiên cứu Việt Nam và thế giới quan tâm đến hệ thống treo bán tích cực. Bài báo này giới thiệu phương pháp điều khiển cân bằng được sử dụng cho hệ thống treo bán tích cực với hai chiến lược điều khiển bao gồm bộ điều khiển cân bằng on-off và liên tục. Ý tưởng chính của chiến lược này là lực giảm chấn được điều khiển thay đổi sao cho có biên độ bằng với lực của lò xo nhưng ngược dấu. Điều này sẽ giảm gia tốc thẳng đứng của thân xe. Kết quả mô phỏng trên miền thời gian chỉ rõ rằng bằng cách sử dụng phương pháp điều khiển cân bằng, giá trị sai lệch bình phương trung bình của dịch chuyển thân xe, góc lắc dọc thân xe và gia tốc của chúng giảm từ 25% đến 50% so với hệ thống treo bị động.

Từ khóa: *Động lực học ô tô; Điều khiển cân bằng; Độ êm dịu; Hệ thống treo; Hệ thống treo bán tích cực.*

Ngày nhận bài: 14/11/2019; Ngày hoàn thiện: 22/02/2020; Ngày đăng: 26/02/2020

Email: vvtan@utc.edu.vn

<https://doi.org/10.34238/tnu-jst.2020.02.2332>

1. Introduction

The modern vehicle is an extremely complex system which consists of multi-subsystems in order to enhance driving comfort, stability and safety, thanks to either passive or active solutions using various actuators. Together with many recent breakthroughs in the automotive industry, many studies have been fulfilled on either the suspension control aspects or the steering-braking control strategies, or a combination of them [1], [2]. When driving, the road surface is the main source of disturbance causing vehicle vibration that influences driver and passengers. That is why when we travel by cars, many people get car sick or tired. The study of suspension systems is one of the most effective ways to improve ride comfort. There are currently three main types of suspension system, the first being a passive suspension fitted with a damper and an elastic element, the second being an active suspension fitted with active actuators- this type usually consumes a lot energy and high price, the third type is semi-active suspension system. Because of economical energy consumption and good ride quality, the semi-active suspension system is a key interest for many researchers.

Semi-active suspension systems have been studied since 1970 [1]. Nowadays they are quite popular in modern vehicles with the layout as shown in Figure 1. Several control design problems for suspension system have then been tackled with various approaches during the last decades. In [3], the authors presented several control strategies for semi-active suspension system (based on the Sky-hook, Ground-hook, ADD, and LPV approach). Some other works using a quarter car model have dealt with optimal control in [4], adaptive control in [5] or robust linear control in [6]. Suspension control problems have also been resolved using a half car model as in [7] using an optimal control, [8]

multi-objective control and [9] decoupling strategies. In addition, fuzzy control is also interested by many authors. Finally, a full car vertical model has been considered to handle simultaneously the bounce, pitch and roll motions, as in [10] using a mixed H_2/H_∞ multi-objective control, and in [11], [12] developing H_∞ controllers for two decoupled vehicle heave-pitch and roll-warp subsystems. In addition, the study of actuators for semi-active suspension is also carried out on two typical types: ER and MR dampers [13], [14], [15].

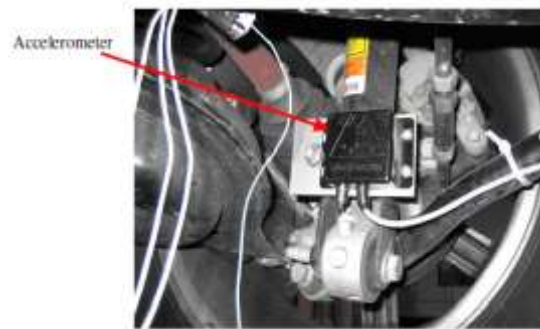

Figure 1. *Controlled suspension system in a car*

The main contribution of this paper is to propose a new balance control strategy to enhance the car vertical dynamics (ride comfort) using suspension actuators only. The half car model is used to evaluate the effect of the proposed method. The simulation results show that the Root Mean Square of the vertical acceleration and pitch acceleration of the vehicle body according to random disturbance is reduced 25-30%, compared to the passive suspension system.

The paper is structured as follows. Section 2 is devoted to the brief description of the half vehicle model used for synthesis and validation. Section 3 presents the balance control strategy with the aim of enhancing the car ride comfort. Section 4 describes the simulation analysis in the time domain. Finally, some conclusions are given in the last section.

2. Vehicle modelling

In this work, a half car vertical model is used for the analysis and control of the vehicle

dynamic behaviors as shown in Figure 2. The model has 4 degrees of freedom: vertical displacement of center of gravity Z_3 , pitch angle ϕ and vertical displacements of unsprung masses Z_1, Z_2 . f_{d1} and f_{d2} are the damping forces from the semi-active dampers.

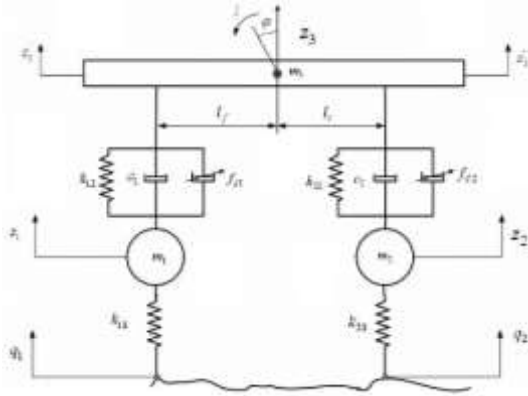

Figure 2. Half vehicle longitudinal model

The dynamic equations are given as:

$$\begin{cases} J \ddot{\phi} = - \left[k_{12} \cdot (Z_1 - Z_3) + c_1 \cdot (\dot{Z}_1 - \dot{Z}_3) \right] J_f \\ \quad + \left[k_{22} \cdot (Z_2 - Z_3) + c_2 \cdot (\dot{Z}_2 - \dot{Z}_3) \right] J_r - l_f \cdot f_{d1} + l_r \cdot f_{d2} \\ m_3 \ddot{Z}_3 = k_{12} \cdot (Z_1 - Z_3) + k_{22} \cdot (Z_2 - Z_3) \\ \quad + c_1 \cdot (\dot{Z}_1 - \dot{Z}_3) + c_2 \cdot (\dot{Z}_2 - \dot{Z}_3) - f_{d1} - f_{d2} \\ m_1 \ddot{Z}_1 = -k_{11} \cdot (Z_1 - q_1) + k_{12} \cdot (Z_1 - Z_3) + c_1 \cdot (\dot{Z}_1 - \dot{Z}_3) + f_{d1} \\ m_2 \ddot{Z}_2 = -k_{21} \cdot (Z_2 - q_2) + k_{22} \cdot (Z_2 - Z_3) + c_2 \cdot (\dot{Z}_2 - \dot{Z}_3) + f_{d2} \end{cases} \quad (1)$$

$$\text{where: } \begin{cases} Z_1 = Z_3 - \phi \cdot l_f \\ Z_2 = Z_3 + \phi \cdot l_r \end{cases} \quad (2)$$

Equation (1) can be written in the State-Space representation:

$$\begin{cases} \dot{x} = A \cdot x + B \cdot u \\ Z = C \cdot x + D \cdot u \end{cases} \quad (3)$$

where: $x = \left[\phi \ Z_3 \ Z_1 \ Z_2 \ \dot{\phi} \ \dot{Z}_3 \ \dot{Z}_1 \ \dot{Z}_2 \right]^T$: the

state vector; $Z = \left[\ddot{\phi} \ \ddot{Z}_3 \ F_1 \ F_2 \right]^T$: the output

vector; $F_1 = k_{11} \cdot (Z_1 - q_1)$: the dynamic wheel load at the front axle; $F_2 = k_{21} \cdot (Z_2 - q_2)$:

the dynamic wheel load at the rear axle; $u = \left[f_{d1} \ f_{d2} \ q_1 \ q_2 \right]^T$: the input vector (disturbance).

The parameters and symbols of this model are shown in Table 1.

Table 1. Parameters of the half vehicle model

Description	Symbols	Value	Unit
Unsprung mass at the front axle/rear axles	m_1/ m_2	36/36	kg
Sprung mass	m_3	540	kg
Moment of inertia	J	$14 \cdot 10^3$	kgm^2
Stiffness coefficient of the front/rear tyres	k_{11}/ k_{21}	$16 \cdot 10^4 / 16 \cdot 10^4$	N/m
Stiffness coefficient of spring at the front/rear axles	k_{12}/ k_{22}	$16 \cdot 10^3 / 16 \cdot 10^3$	N/m
Damping coefficient at the front/rear axles	c_1/ c_2	1400/ 1400	N.s/m
CG distance from the front/rear axles	l_f/ l_r	1,6/1,4	m

3. The balance control strategy for semi-active suspension system

In order to design the balance controller for the semi-active suspension system with the half vehicle model as Figure 2, in this section we consider a simple quarter car model (Figure 3.a) with the disturbance $x_0(t)$, the stiffness coefficient of spring k and the damping coefficient c.

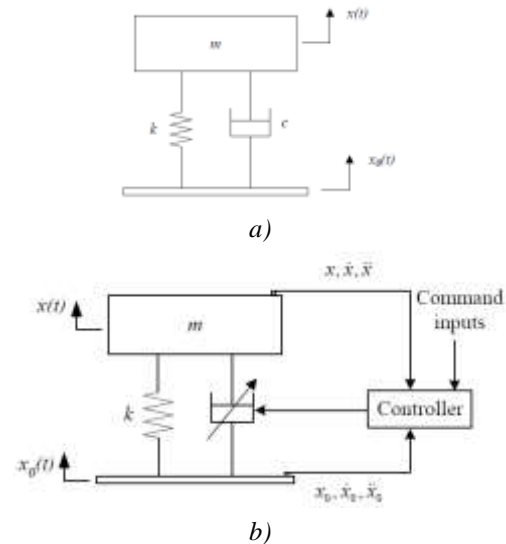

Figure 3. A simple quarter car model:

- a) Passive suspension system
- b) Semi-active suspension system

The dynamic equation is given in the following form:

$$m \cdot \ddot{x} + F_k + F_d = 0 \quad (4)$$

where: F_k and F_d are the spring and damping forces, respectively.

$$F_k = k(x - x_0) \quad (5)$$

$$F_d = c(\dot{x} - \dot{x}_0) \quad (6)$$

The relations between $m \cdot \ddot{x}$, F_k and F_d in case of a sine wave disturbance are shown in Figure 4.

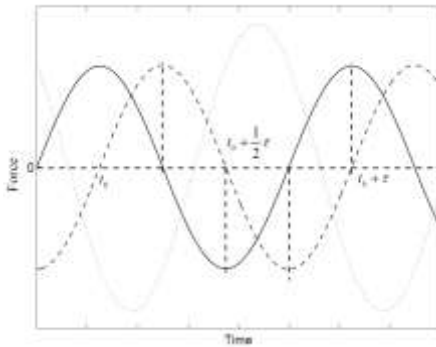

Figure 4. Relation between the forces acting on the sprung mass “m” in case of an harmonized excitation: _____ : Damping force (F_d); - - - - - : Spring force (F_k) and : Inertial force ($m \ddot{x}$)

The amplitude of the acceleration of the sprung mass “m” in the harmonized excitation depends on the damping force and the spring force due to the following equations [12]:

$$\left| \ddot{x} \right| = \frac{|F_k| + |F_d|}{m} \quad \left| \begin{array}{l} t_0 < t < t_0 + \frac{\tau}{4} \\ t_0 + \frac{\tau}{2} < t < t_0 + \frac{3\tau}{4} \end{array} \right. \quad (7)$$

$$\left| \ddot{x} \right| = \frac{|F_k| - |F_d|}{m} \quad \left| \begin{array}{l} t_0 + \frac{\tau}{4} < t < t_0 + \frac{\tau}{2} \\ t_0 + \frac{3\tau}{4} < t < t_0 + \tau \end{array} \right. \quad (8)$$

where: t_0 is the time during, which the spring force is “zero”; τ is the frequency of vibration.

During vibration, one would like to have small \ddot{x} , however in accordance with equations 7, 8 and Figure 4, the rise of the

damping force causes increment of the amplitude of the acceleration in one part of the cycle of vibration. After that the amplitude of \ddot{x} will be reduced if F_k and F_d have the same magnitude. When increasing the excitation frequency, it is dominated by the damping force F_d . In order to reduce the amplitude of the acceleration, a semi-active suspension system is proposed as in Figure 3.b. It might use active or semi-active dampers, which can be hydraulic damper with throttle, friction damper, MR damper, ER damper, electromagnetic damper, etc. Here, we would like to consider a new balance control strategy, which combines the harmony of the three forces mentioned above.

This strategy maintains that the damping force increases the acceleration of the sprung mass when the damping force and the spring force have the same sign. There are 2 states of damper: On state and Off state. The “off” state is existed when the damping and spring forces acting on the sprung mass have the same direction ($(x - x_0)(\dot{x} - \dot{x}_0) > 0$), and vice versa at the “on” state when ($(x - x_0)(\dot{x} - \dot{x}_0) \leq 0$). Therefore, the damping force is against the spring force and the strategy is called the Balance Control.

3.1. The continuous balance control strategy

In order to maintain the equality of damping and spring forces at the “on” state, the damping force from the semi-active damper

$$F_{SA} = \begin{cases} -k(x - x_0) & (x - x_0)(\dot{x} - \dot{x}_0) \leq 0 \\ 0 & (x - x_0)(\dot{x} - \dot{x}_0) > 0 \end{cases} \quad (9)$$

Therefore, the damping coefficient of the semi-active damper is defined in equation (10) and shown in Figure 5.

$$C_{SA} = \begin{cases} \frac{-k(x - x_0)}{\dot{x} - \dot{x}_0} & (x - x_0)(\dot{x} - \dot{x}_0) \leq 0 \\ 0 & (x - x_0)(\dot{x} - \dot{x}_0) > 0 \end{cases} \quad (10)$$

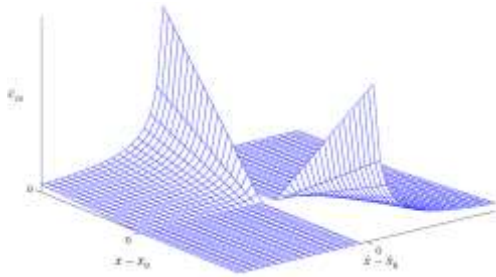

Figure 5. The value of C_{SA} with respect to $(x - x_0)$ and $(\dot{x} - \dot{x}_0)$

We can see that when the relative velocity $(\dot{x} - \dot{x}_0)$ is very small, the damping coefficient is closed to infinity, which cannot happen for the real damper. Therefore, the damping coefficient for the semi-active damper C_{SA} must continuously vary within the interval (C_{max}, C_{min}) according to the manufacturer’s desire. The value of C_{SA} can be determined as the following:

$$C_{SA} = \begin{cases} \max \left[C_{min}, \min \left[\frac{-k \cdot (x - x_0)}{\dot{x} - \dot{x}_0}, C_{max} \right] \right] & (x - x_0)(\dot{x} - \dot{x}_0) \leq 0 \\ C_{min} & (x - x_0)(\dot{x} - \dot{x}_0) > 0 \end{cases} \quad (11)$$

In this case, the value of the damping force is plotted as Figure 6.

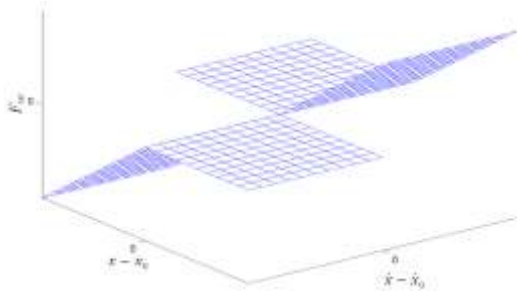

Figure 6. Damping force F_{SA} with respect to $(x - x_0)$ and $(\dot{x} - \dot{x}_0)$ in case of the continuous balance control

3.2. The “On-off” balance control strategy

The “on-off” balance control strategy is studied to simplify the working of the damper. In the two states, the semi-active damper is controlled at the maximum state or the minimum state (high and low states), correspondingly. In this case, the damping force is determined as:

$$F_{SA} = \begin{cases} C_{on}(\dot{x} - \dot{x}_0) & (x - x_0)(\dot{x} - \dot{x}_0) \leq 0 \\ 0 & (x - x_0)(\dot{x} - \dot{x}_0) > 0 \end{cases} \quad (12)$$

where: C_{on} is the damping coefficient of the “on-off” damper at the “on” state.

The relation between the damping force in the “on-off” balance control with $(x - x_0)$ and $(\dot{x} - \dot{x}_0)$ is shown in Figure 7.

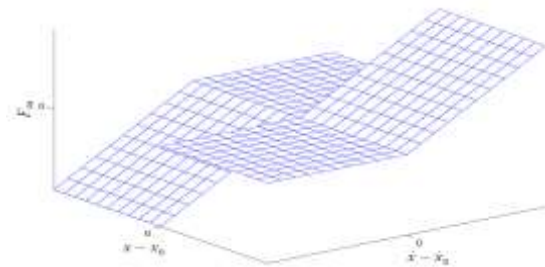

Figure 7. Damping force F_{SA} with respect to $(x - x_0)$ and $(\dot{x} - \dot{x}_0)$ in case of the “on-off” balance control

4. Simulation analysis

In this section, we evaluate the effect of the proposed controller in order to improve ride comfort. The two controllers (continuous and On-Off Balance Control strategies) are compared with the passive suspension system.

4.1. Road surfaces

When a car is moving on the road, the road profile is a random form with the frequency range from 0 to a maximum of 20 Hz. In this study, the author uses three basic types of the road profile: step, sine wave and random to evaluate the controller performance. They are described as in Figure 8 [16].

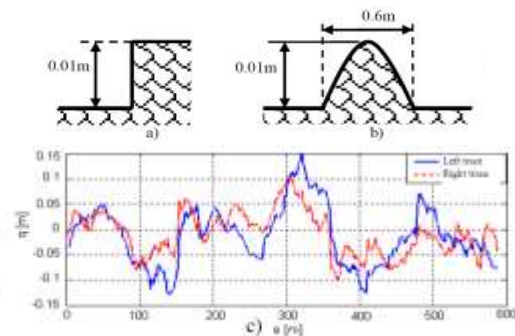

Figure 8. Road profiles: a) Step profile, b) Sine wave profile, c) Random profile

4.2. Evaluation criteria

The ride comfort level is evaluated by Root Mean Square (RMS) of the vertical acceleration ($RMS(\ddot{Z}_3)$) and pitch acceleration ($RMS(\ddot{\phi})$) of the vehicle body according to the random profile and the amplitude peaks with the step and sine wave profiles. Moreover, the Root Mean Square of the dynamic wheel loads at the two axles are used to assess the road handling characteristic.

$$RMS(\ddot{Z}_3) = \sqrt{\frac{\sum_{j=0}^T (\ddot{Z}_{3j})^2}{T}} \quad (13)$$

$$RMS(\ddot{\phi}) = \sqrt{\frac{\sum_{j=0}^T (\ddot{\phi})^2}{T}} \quad (14)$$

4.3. Results and evaluations of the balance control strategies

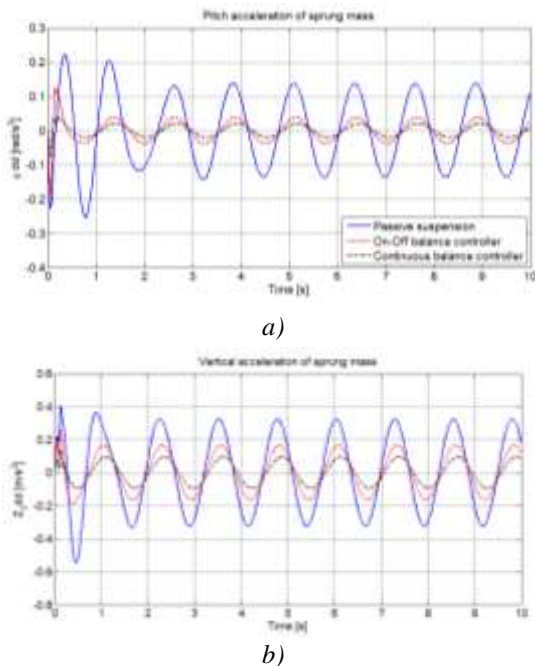

Figure 10. Time response of the sprung mass

Figure 10 shows the time response of the sprung mass including vertical displacement, pitch angle accelerations. In this case, the vehicle speed is considered at 54 km/h, with the sine wave road profile at the frequency of

5 rad/s. The solid line represents the case of the passive suspension, the dashed line represents the On-Off balance control case, and the dashed-dotted line is the continuous balance control case. The simulation results show that the active control system using balance controllers with this type of road profile is reduced by 50%, compared with the passive suspension system.

In order to accurately assess the effectiveness of the proposed control method, the author uses two important criterias: the amplitude from the peak to the peak of the signals and their root mean square. The road surface in this case is a random profile of the national road Ha Noi - Lang Son as shown in Figure 8c. The vehicle speed in this case is 72 km/h. Figure 11 shows the result of the comparison between the three cases: semi-active suspension using the two balance controllers and the passive suspension system. Here, please understand that the signals regarding the passive suspension system are considered of 100%.

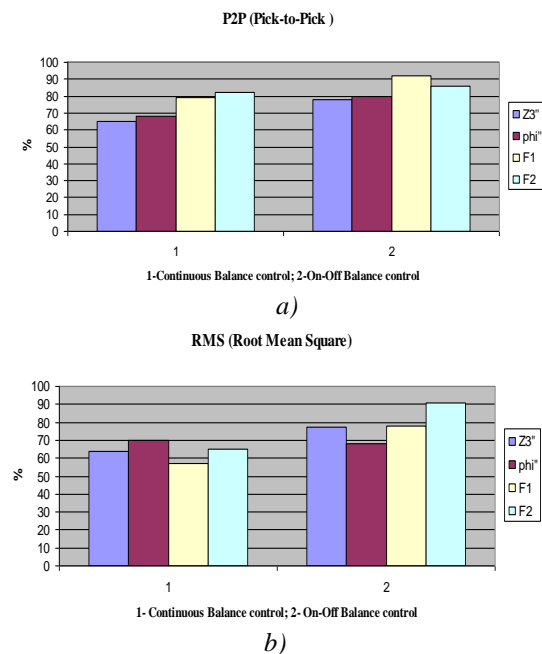

Figure 11. Comparisons between semi-active suspension system using balance control strategies and passive suspension system: (a- Step profile; b- Random profile)

It is indicated in the results that ride comfort criteria values in the case of semi-active suspension system using balance control strategies are smaller than the ones of passive suspension system (100%). For the continuous balance control strategy $RMS(\ddot{Z}_3)$, $RMS(\ddot{\varphi})$ are just 70%, and 75% in comparison with the “on-off” balance control strategy. In addition, the simulation result of the dynamic forces ($F_{1,2}$) between the wheels and the road shows that the use of the semi-active suspension system also increases the road holding criteria, which increases car safety during vehicle motion.

5. Conclusion

Semi-active suspension system has been studied extensively worldwide to improve ride comfort of cars. The present paper introduces the continuous and “on-off” balance control strategies. The simulation results in the case of 4-degree of freedom car model showed the efficiencies of the control balance strategies in order to enhance ride comfort, compared with the passive suspension system. With a reduction by 25-50% of the root mean square of the corresponding signals, it has been shown that the balanced control method can achieve the same effect as the advanced control method such as the optimal control, robust control, etc. Meanwhile, this method is much simpler in its application.

REFERENCES

- [1]. P. Gaspar, Z. Szabo, J. Bokor, C. Poussot-Vassal, O. Sename, and L. Dugard, “Toward global chassis control by integrating the brake and suspension systems,” in Proceedings of the 5th IFAC Symposium on Advances in Automotive Control, AAC, California, US, 2007, pp. 563-570.
- [2]. C. Poussot-Vassal, O. Sename, L. Dugard, P. Gaspar, Z. Szabo, and J. Bokor, “Attitude and handling improvements through gain-scheduled suspensions and brakes control,” *Control Engineering Practice*, vol. 19, no. 3, pp. 252-263, 2011.
- [3]. S. M. Savaresi, C. Poussot-Vassal, C. Spelta, O. Sename, and L. Dugard, *Semi-active suspension control design for vehicles*. Elsevier, 2011. [Online]. Available: <https://www.sciencedirect.com/book/9780080966786/semi-active-suspension-control-design-for-vehicles>. [Accessed Jan 15, 2017].
- [4]. D. Hrovat, “Survey of advanced suspension developments and related optimal control applications,” *Automatica*, vol. 33, no. 10, pp. 1781-1817, 1997.
- [5]. G. Koch and T. Kloiber, “Driving state adaptive control of an active vehicle suspension system,” *IEEE Transactions on Control Systems Technology*, vol. 22, no. 1, pp. 44-57, 2014.
- [6]. C. Lauwerys, J. Swevers, and P. Sas, “Robust linear control of an active suspension on a quarter car test-rig,” *Control Engineering Practice*, vol. 13, no. 5, pp. 577-586, 2005.
- [7]. R. Krtolica and D. Hrovat, “Optimal active suspension control based on a half-car model,” in Proceedings of the 29th IEEE Conference on Decision and Control. IEEE, 1990, pp. 2238-2243.
- [8]. P. Y. Sun and H. Chen, “Multiobjective output-feedback suspension control on a half-car model,” in Proceedings of 2003 IEEE Conference on Control Applications, IEEE, 2003, pp. 290-295.
- [9]. Y. Zhang and A. Alleyne, “A new approach to half-car active suspension control,” in American Control Conference, Colorado, US: IEEE, 2003, pp. 3762-3767.
- [10]. J. Lu and M. DePoyster, “Multiobjective optimal suspension control to achieve integrated ride and handling performance,” *IEEE Transactions on Control Systems Technology*, vol. 10, no. 6, pp. 807-821, 2002.
- [11]. D. C. Karnopp, M. J. Crosby, and R. A. Harwood, “Vibration control using semi-active force generators,” *ASME Journal of Engineering for Industry*, vol. 96, no. 10, pp. 619-626, 1974.

-
- [12]. S. Rakheja and S. Sankar, "Vibration and shock isolation performance of asemitive "on-off" damper," *ASME Journal of Vibration, Acoustics, Stress, and Reliability in Design*, vol. 107, pp. 398-403, 1985.
- [13]. T. Sireteanu, D. Stancioiu, and C. W. Stammers, "Use of magnetorheological fluid dampers in semi-active driver seat vibration control", in ACTIVE 2002, ISVR, Southampton, UK, 2002.
- [14]. E. J. Krasnicki, "The experimental performance of an "on-off" active damper," in Proceedings of the 51st Shock and Vibration Symposium, San Diego, USA, 1980, pp. 159-164
- [15]. J. Alanoly and S. Sankar, "A new concept in semi-active vibration isolation", *ASME Journal of Mechanisms, Transmissions, and Automation in Design*, vol. 109, pp. 242-247, 1987.
- [16]. M. H. Dao, V. N. Tran, V. B. Nguyen, and T. H. Cao, *Study the influence of road profile on loads acting on vehicle in 1A Ha Noi - Lang Son Highway*, Ministry Research, Ha Noi, 2005.