

# DEVELOPMENT OF ALGORITHM TO IDENTIFY THE GLOBAL OPTIMIZED POINT OF SOLAR PHOTOVOLTAICS PANEL UNDER THE CONDITION OF NON-UNIFORM SOLAR ARRAY ON THE SURFACE

PHÁT TRIỂN THUẬT TOÁN XÁC ĐỊNH ĐIỂM TỐI ƯU TOÀN CỤC CỦA PIN MẶT TRỜI TRONG ĐIỀU KIỆN CHIẾU SÁNG KHÔNG ĐỒNG NHẤT TRÊN BỀ MẶT

Nguyen Duc Minh<sup>1</sup>, Do Nhu Y<sup>2</sup>,  
Trinh Trong Chuong<sup>3,\*</sup>

## ABSTRACT

Maximum Power Point Tracking (MPPT) is a good technique to improve the efficiency of the solar PV system. The solar PV system can operate at the maximum capacity with MPPT. In practice, it is easy to identify the maximum capacity in the non-linear P-V curve under the condition of continuous irradiance with the popular MPPT methods. However, it is difficult to track the real MPPs with MPPT, under the condition of partial shading, due to many local maximum power points (LMPPs). In this paper, a new method is presented to track the global maximum power points (GMPPs) of the solar PV system.

Compared with the popular existing MPPT techniques, the proposed method in this paper has an additional advantage as follows: under the condition of partial shading, the proposed method will forecast the positions of GMPPs and LMPPs on the P-V curve. The new method can quickly identify the GMPPs and avoid the energy loss due to blind scanning under the condition of partial shading. The experiment results verify that the proposed method guarantees convergence of the GMPPs under partial shading conditions.

**Keywords:** MPPT, Photovoltaics, GMPP, P&O, GA.

## TÓM TẮT

Sử dụng kỹ thuật bám theo điểm công suất cực đại (Max Power Point Tracking - MPPT) là một kỹ thuật tốt để nâng cao hiệu quả của hệ thống PV. Hệ thống PV có thể hoạt động với công suất tối đa bằng MPPT. Trên thực tế, có thể dễ dàng tìm ra công suất lớn nhất trong đường cong phi tuyến P-V dưới bức xạ liên tục bằng các phương pháp MPPT phổ biến. Tuy nhiên, MPPT có thể rất khó để theo dõi MPP thực tế trong điều kiện bóng mờ một phần do có nhiều các điểm công suất cực đại địa phương. Trong bài báo này, một phương pháp mới đã được trình bày để theo dõi điểm công suất cực đại toàn cục (Global Maximum Power Point - GMPP) của PV.

So với các kỹ thuật tìm MPPT phổ biến đã được đề xuất trước đây, phương pháp được đề xuất trong bài báo này có thêm những ưu điểm đó là khi nào có xuất hiện hiện tượng bóng che từng phần, phương pháp này sẽ dự đoán vị trí của GMPP và LMPP trên đường đặc tính P-V. Phương pháp mới có thể nhanh chóng xác định GMPP và tránh mất năng lượng do quét mù. Các kết quả thử nghiệm xác minh rằng phương pháp được đề xuất đảm bảo sự hội tụ với MPP toàn cục trong điều kiện bóng che từng phần.

**Từ khóa:** MPPT, Pin mặt trời, GMPP, P&O, GA.

<sup>1</sup>Institute of Energy Science, Vietnam Academy of Science and Technology

<sup>2</sup>Hanoi University of Mining and Geology

<sup>3</sup>Hanoi University of Industry

\*Email: chuonghtd@hau.edu.vn

Received: 01/10/2020

Revised: 15/11/2020

Accepted: 23/12/2020

## 1. INTRODUCTION

Maximum Power Point Tracking (MPPT) techniques for solar PV are increasingly completed and applied [1-3]. Many studies are proposing new MPPT algorithms, allowing the

tracking of MPPs under the condition of fluctuating environment temperature and irradiance [5-6], grid-connected solar PV [7], grid-connected solar PV with fluctuating loads and voltages [8]. Recommended MPPT

algorithms are various and effective, including popular algorithms such as Perturb and Observe (P&O) and Incremental Conductance (INC) [9], adaptive back-propagation MPPT algorithm [10], extremum seeking MPPT algorithm [11], geometric sliding mode control MPPT algorithm [12], and various MPPT algorithms. Recently, the conventional P&O and INC MPPT algorithms have shown to be promising. Femia et al. proposed the forecasted adaptive P&O MPPT algorithm [13]. Zhang et al. proposed improved P&O MPPT algorithm with adjustable perturb [14].

Authors in [15-16] introduced the improved INC MPPT with adaptive perturb step Improved Incremental Conductance Method. At the same time, the intelligent MPPT algorithms based on neural model [17-18], fuzzy model show some effectiveness in maintaining the optimized MPPT operation of the solar PV system under fluctuating condition [19 - 20]. Based on these literatures, the paper proposed a new algorithm adaptive Fuzzy P&O MPPT, which allows to flexibly adjust the perturb step of the conventional P&O algorithm. The new adaptive Fuzzy P&O MPPT has the outstanding quality compared to the conventional P&O MPPT algorithm, stably operating throughout the whole working area of the solar PV system, completely eliminating perturb around the MPP working point as well as allowing to accelerate the convergence speed to the MPP working point when the environment temperature and irradiance fluctuate.

In case of non-uniform solar irradiance due to the uneven irradiance of the panels due to partial shading influence, the common MPPT algorithms are trapped in the local peak, without detecting the maximum power points. Therefore, the GMPPT techniques have been studied and developed to identify the maximum power points under shading conditions, such as Particle Swarm Optimization (PSO), Improved PSO, Artificial Bee Colony, Ant Colony Optimization, Simulated Annealing, Bat Algorithm, Firefly Algorithm (FFA), Fireworks Algorithm (FWA), Glow-worm Swarm Optimization (GSO), S-Jaya Algorithm, Flower Pollination Algorithm (FPA), Grey Wolf Optimization (GWO), Teaching Learning Based Algorithm (TLBO), Mine Blast Algorithm (MBA), Whale Optimization Algorithm (WOA), Human Psychology Optimization (HPO), etc. These algorithms can solve multi-peak GMPPT problems and are highly efficient. However, the performance of one algorithm can be further improved.

Recently, hybrid methods have been applied by combining two or more methods in order to further improve the efficiency. The newly developed hybrid methods combine conventional algorithms with intelligent algorithms such as Firefly Algorithm in combination with Incremental Conductance (INC-FFA), P&O in combination with neural network (P&O-ANN), Fireworks Algorithm in combination with P&O (FWA-P&O), Grey Wolf Optimization in combination with P&O (GWO-P&O), Bat Algorithm in combination with P&O (Bat-P&O), Particle Swarm Optimization in combination with P&O (PSO-P&O); or

combine two or more intelligent algorithms like Simulated Annealing in combination with Particle Swarm Optimization (SA-PSO), Fish Swarm in combination with PSO, Jaya algorithm in combination with Differential Evolution (Jaya-DE), Whale Optimization in combination with Differential Evolution (WODE) and PSO in combination with Shuffled Frog Leaping Algorithm (PSO-SFLA), etc. In addition to the mentioned methods, there are other GMPPT techniques to solve the partial shading problems, for examples, the method based on the transient evolution of series capacitors, equilibrium curve, proactive feedback of shaded cells, two-stage seeking, repeated scan and track, stepwise comparison search, beta algorithm, Fibonacci search algorithm, extremum seeking.

In this paper, the method to identify and solve the shading problem in one solar panel will be presented. The paper aims at examining a diagram to obtain the maximum solar irradiance to a solar PV panel for DC application.

## 2. GENETIC ALGORITHM

Genetic Algorithm (GA) is a technique based on Darwin's theory on natural evolution. It is the random optimization selection by imitating the human or biological evolution. The nature of the GA is to simulate natural phenomenon which is inheritance and survival fight. GA is one of strong algorithms, but it is different from random algorithms, because it combines direct and random searching objects. Another important difference between GA's search and that of other algorithms is that GA remains and processes a set of solutions, called population.

In GA, the search for a suitable hypothesis begins with an initial population or a selective set of hypotheses. Individuals of the present population initially create the next generation population through random mutation and hybridization activities - being sampled after biological evolutionary processes. At each step, the hypotheses in the present population are estimated in relation to the adaptive quantity, and the most suitable hypotheses are selected by the probability of being the seeds for producing the next generation, called individuals. The individuals which are more developed and adaptive to the environment, will survive; and vice versa, the inferior will be discarded. GA can detect the next generation with better adaptability.

The use of GA requires to define the initial population, the fitness function to evaluate the solutions by the adaptive level - the objective function, the genetic operators to create the reproduction function.

The general GA diagram is presented in Figure 1. GA belongs to the evolutionary algorithm class, which is used to simulate and solve optimization problems by applying a group of solutions called population. In other words, GA solves a problem being coded into a string of characters. GA is largely different from other algorithms as it combines direct and random searching elements. As a consequence, it has the advantage of error and the ability to find the global maximum.

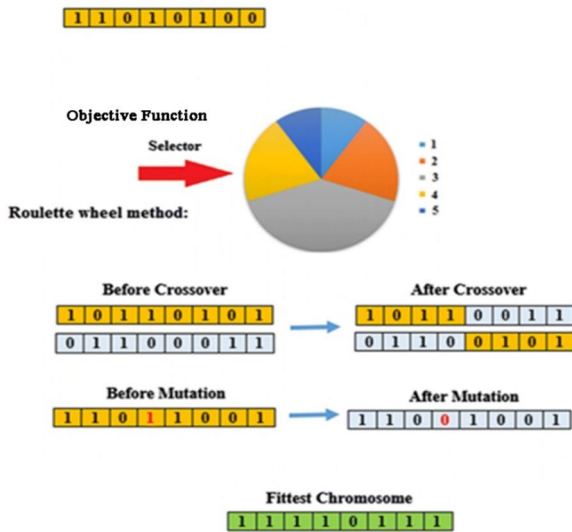

Figure 1. Description of GA

The differences between GA and other optimization algorithms include:

- GA works with code of variables instead of working directly on variables.
- Most common optimization techniques search from a peak, meanwhile GA always works on a set of peaks (optimization points), which is an advantage of GA to avoid early convergence at local maximum power point.
- GA evaluates the objective function to serve for searching process, so it can be applied on any optimization problem (continuous or discontinuous).
- GA belongs to the class of probability algorithms; the basic steps of GA are based on random integration ability during the processing stage.

GA simulates the natural evolution and selection by starting with a random population. However, apart from the above advantages, GA itself still has some limitations such as slow convergence speed, poor detection in the neighbouring area, and early convergence. Therefore, there are several studies to overcome these limitations by combining it with other genetic or mathematical algorithms. The problems of MPPT under shading conditions are the problems of optimization and search in narrow spaces. The position of the working point on a bi-dimensional space depends on two variables of the pulse cycle coefficient and the obtained power ( $D$ ;  $P$ ). The proposed algorithm in this paper will focus on improving the traditional GA algorithm based on the two following points:

- With the problem characteristics of working in a narrow search space, it is proposed to use a two-generation selection method. The best individuals which are selected in the previous cycle, are kept for the selective evaluation together with hybridized and mutated individuals for the next cycle. Thus, the survey and evaluation of the individuals and the selection of the best individuals will be more accurate, increasing the ability to detect around the

extreme area. However, this method requires the storage of larger populations than the traditional GA. Therefore, it is only suitable for narrow spaces and small-scale populations. In addition, in order to achieve the essential accuracy, this method requires that the investigating space remains unchanged in the process of searching for the maximum points.

- In some cases, the working points do not change although the shading conditions change, and the solar radiations change. In these case, the partial shading occurs strongly, dividing the PV series into two nearly independent working areas. As a consequence, when there is no shading, the obtained power in the low-irradiance area increases, but the P-V characteristic of the high-irradiance area is not affected. This significantly affects the ability of post-configuration optimization of the system because the evaluation of the irradiance changes is entirely based on the change of the working point. Therefore, it is necessary to periodically mutate after the configuration.

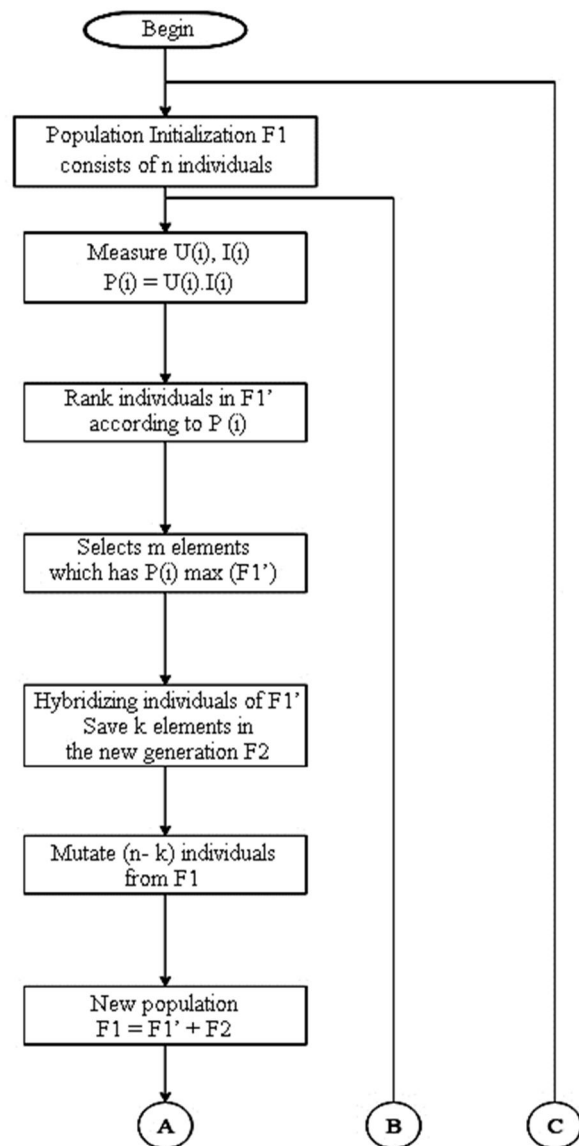

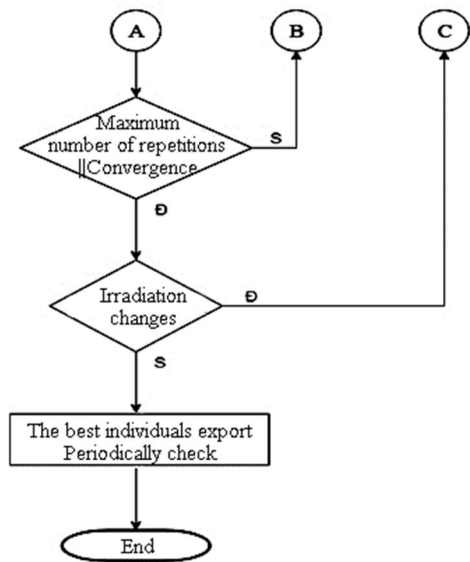

Figure 2. Diagram of proposed GA

In which:

- F1: The initial generation to survey and select individuals. From the second cycle, F1 includes the selected individuals of the previous cycle and the newly mutated and hybridized generation of the selected individuals.
- F1': The best individuals selected from F1.
- F2: New generation established by mutating and hybridizing individuals of F1'.
- U(i), I(i), P(i): Voltage, Current and Power of individual i.

**3. SIMULATION RESULTS**

**3.1. Simulation modelling**

The proposed algorithm is simulated and tested the ability to detect the maximum power points in a set of five solar panels connected in series under the conditions of different solar radiation, with the application of PSIM software. The simulated circuit diagram, with the use of DC boost converter is presented in Figure 3.

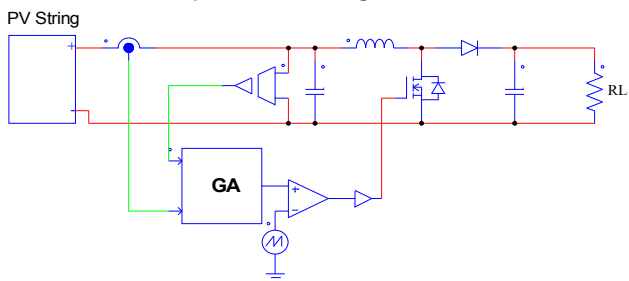

Figure 3. Simulation diagram with PSIM

The panels which are used in the simulation model, are based on the Green Wing module GW - BD16/72, with the max power of 310W and the parameters under test conditions as follows: Battery type: monocrystalline (Mono). Numbers of photovoltaic cells in one module: 72. Voltage at MPP:  $V_{MPP} = 38.2V$ . Current at MPPT:  $I_{MPP} = 8.9A$ . Open circuit voltage: 46.2V. Short circuit current: 9.5A. Heat coefficient according to  $V_{oc}$ :  $-0.29\%/^{\circ}C$

Parameters of components in the simulated circuit of DC boost converter: Coil inductance: 0.1mH. Input capacitor: 80uF. Output capacitor: 10uF. Switching frequency: 50kHz. Pulse-width modulation PWM: 0.25%. Measurement cycle: 5ms. Load resistance:  $600\Omega$

**3.2. MPPT simulation results**

The simulation system is tested based on two P - V characteristic states of the solar PV panel series. State 1 has the GMPP on the right, and State 2 has the GMPP near  $0.5V_{oc}$ . All five solar PV panels receive different irradiance intensity creating five maximum points (Figure 4). The irradiance intensity settings for the panels are shown in Table 1. The simulation experiments are conducted by investigating the algorithm in three cases of (1) uniform irradiance, (2) the shading increases from State 1 to State 2, and (3) irradiance recovery from States 2 to State 1. The obtained results on generated power with the application of the proposed algorithm and the adaptive P&O algorithm will be compared under the same conditions.

Table 1. Irradiance intensity for the simulated panel series

Power / Condition	PV 1	PV 2	PV 3	PV 4	PV 5
1	1000	950	900	800	700
2	1000	800	750	450	400

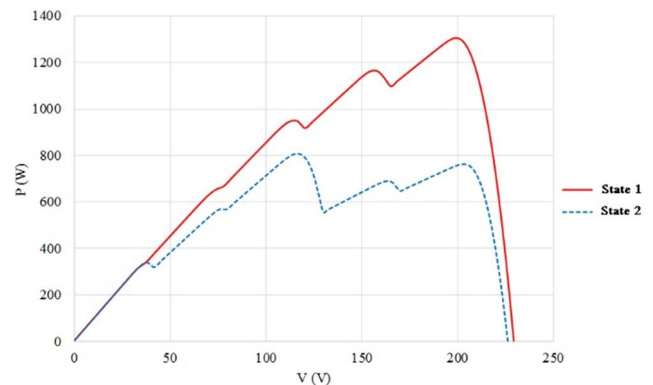

Figure 4. P - V characteristic of two tested states

Figure 5 and 6 present the generated power and voltage with the applications of the two different MPPT algorithms under the uniform irradiance in State 1. According to these two figures, the generated power in the identify state of both algorithms are similar, at 1300W, because the irradiance intensities among the solar PV panels are not largely different and the P&O algorithm start tracking from the right-hand side. The proposed algorithm requires 24 times of changing positions (eight calculation cycle) to get the convergence, meanwhile the P&O algorithm requires only 3 times of irradiance change for the convergence.

Figure 7 and 8 present the generated power and voltage with the applications of the two different MPPT algorithms under the uniform irradiance in State 2.

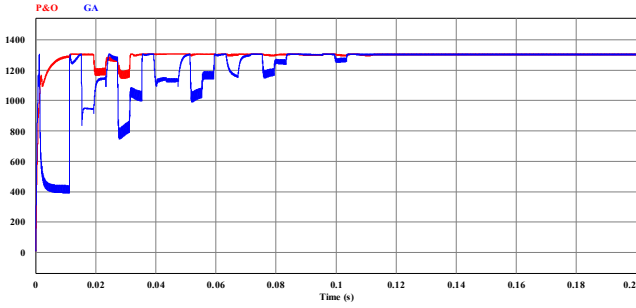

Figure 5. Power of state 1

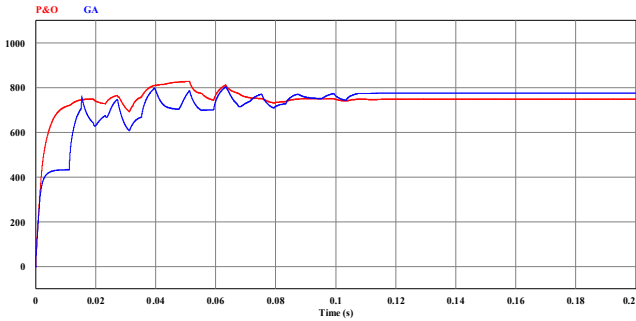

Figure 6. Voltage of state 1

In this experiment, there is a difference in generated power with the applications of the two algorithms. The P&O algorithm is trapped in the local maximum power point, with a power difference of 100W compared to the maximum power of 700W. Meanwhile, the proposed algorithm can correctly detect the GMPP. The convergence time of the P&O algorithm is slower than that of State 1, at one cycle. The convergence time of the proposed algorithm does not change, compared to that of State 1.

In the two cases of irradiance change, the setting of the changing time is 0.2s. The experimental results of the irradiance increase cases with two investigated algorithms are shown in Figure 9 and 10. The process of starting the system within the first 0.2s is the same as those analysed in the experiment of the State 2 with uniform irradiance. After changing the irradiance, the generated power with the application of the proposed algorithm is still the same as those of the State 1 with uniform irradiance. However, with the application of the P&O algorithm, the generated power is 250W lower than the maximum power of State 1 with uniform irradiance. At the same time, the time for MPPT tracking is longer.

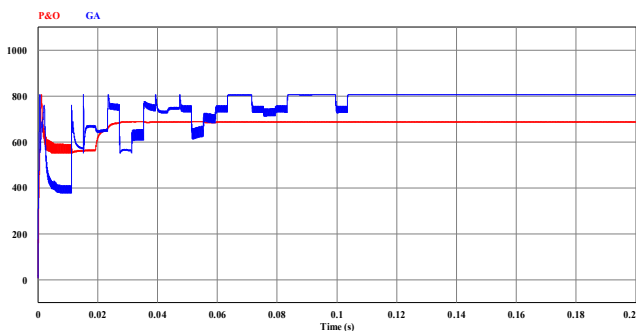

Figure 7. Power of state 2

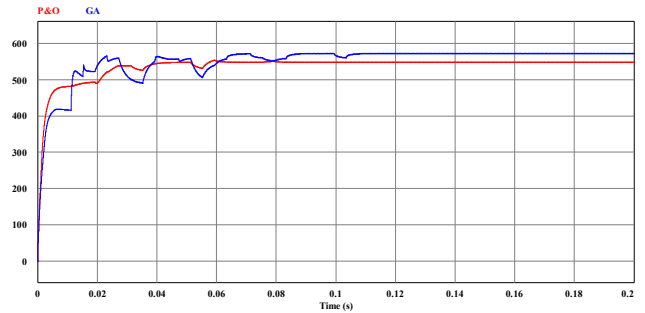

Figure 8. Voltage of state 2

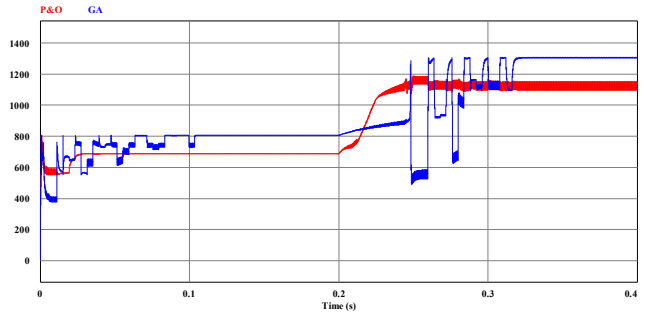

Figure 9. Power of increased irradiance with proposed algorithm

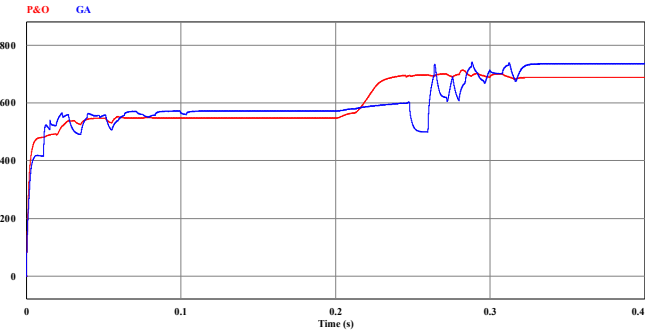

Figure 10. Power of increased irradiance with P&O

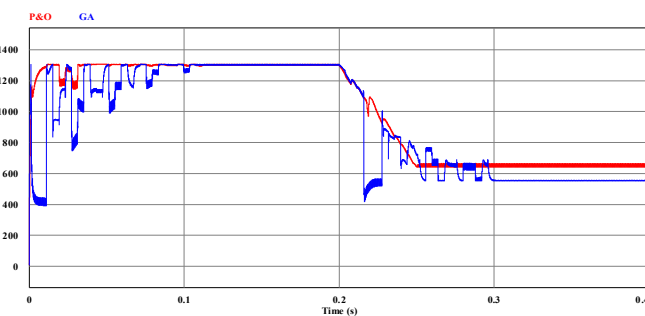

Figure 11. Power of decreased irradiance with proposed algorithm

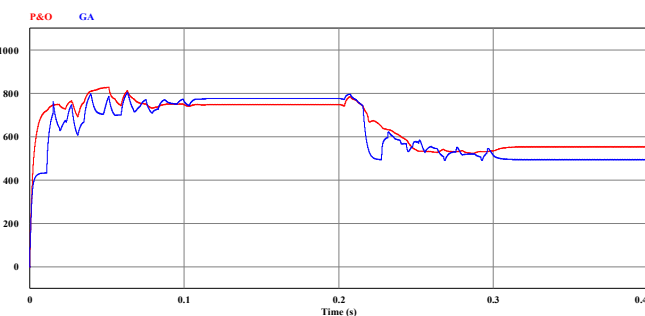

Figure 12. Power of decreased irradiance with P&O

The experimental results of irradiance decrease with the application of the two investigated algorithms are presented in Figure 11, 12. In both states, the P&O algorithm is trapped into the local maximum power points.

In the first case, the power reduces by 10%, at 130W, and in the second case, the power reduces by 20%, at 160W. Time for tracking the MPPs are the same for all experiments, because the algorithm is independent from the gap between the initial point and the maximum point. In these experiments, the tracking time with the application of P&O algorithm is the longest (5 cycles - 0.1s).

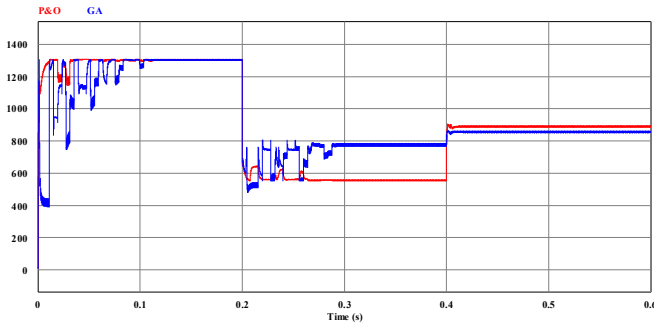

Figure 13. Power of irradiance change for a long period

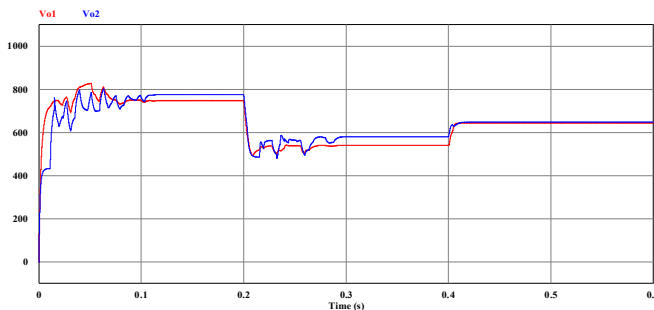

Figure 14. Voltage of irradiance change for a long period

### 3.3. Experiment model

#### 3.3.1. Chroma solar PV simulation

The Chroma Solar experimental model can easily set up the  $V_{OC}$ ,  $I_{SC}$ ,  $V_{mp}$ ,  $I_{mp}$  parameters to simulate the typical output of solar PV cell at fast and stable response time. It can communicate with peripheral devices through connection ports such as Internet, USB, RS-485, RS232, etc.

It is easy to use the software with an intuitive interface (Figure 15). The I-V and P-V characteristic curves can be easily programmed for real-time testing. It also displays MPPT status for PV inverter. The functions of reporting and real-time monitoring are fully displayed on the screen. The time for testing the characteristic curves should be set between 60 and 600 seconds in order to analyse the MPPT efficiency at best. A built-in I-V characteristic in the software allows us to enter the data on the desired maximum input power  $P_{max}$ ,  $V_{min}$ ,  $V_{nom}$ ,  $V_{max}$  to test the PV inverter. We can directly enter the percentage value of the desired maximum power (5%, 10%, 20%, 25%, ..., 50%, 75%, 100%) and the software will automatically generate the I-V characteristic curve of the experimented solar PV cell.

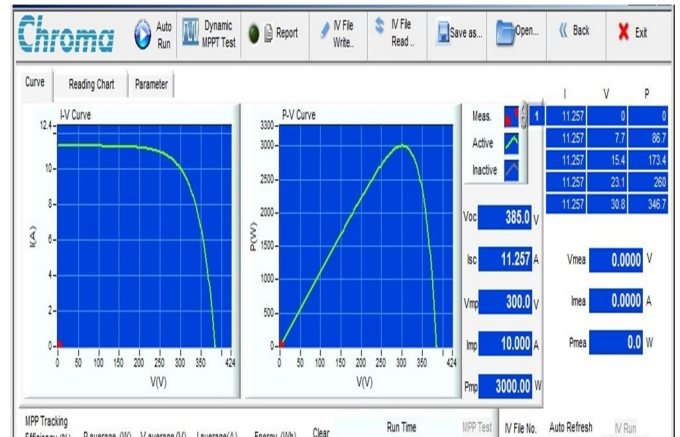

Figure 15. Chroma Array Simulator Interface

#### 3.3.2. DC - DC conversion circuit

A DC - DC voltage conversion circuit according to the principle of the boost circuit has been constructed with the circuit diagram as shown in Figure 16. In addition to the DC - DC boost circuit principle, the experimental circuit uses a voltage divider and a shunt resistor to obtain the voltage and current measurement signals. The circuit parameters are given as follows: Permissible input voltage: 80V; Permissible output voltage: 200V; Rated capacity: 500W; Shunt resistance: 0.05Ω.

The controlling circuit in the article (Figure 17) uses the Arduino Uno microprocessor as the central controller, which is responsible for receiving analog signals, calculating the MPPT algorithm and the PWM that control the MOSFETs respectively. The voltage reading pins of Arduino are taken directly from the dynamic circuit, and the current reading pins are taken from the current signal amplified by the opto amp amplifier. PWM signals which are taken from Arduino, do not have sufficiently minimum voltage to excite the MOSFET (10V), so the paper uses the TLP250 optical opto dedicated to excite the MOSFET. The supply power for the controlling circuit is taken from the grid through the adapter, providing the voltage of 9V for Arduino and 15V for the MOSFET switching excitation circuit (Figure 16).

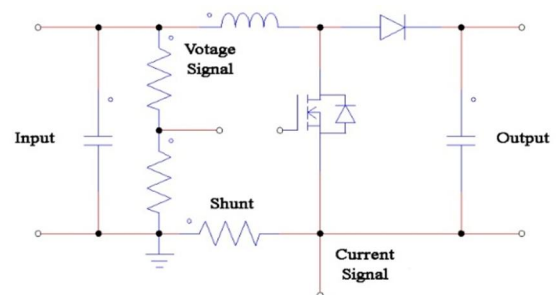

Figure 16. Diagram of experimental dynamic circuit

#### 3.3.3. Controlling circuit

Diagram of experimental Controlling circuit as shown in Figure 17. The components of the designed circuit are presented in Table 2.



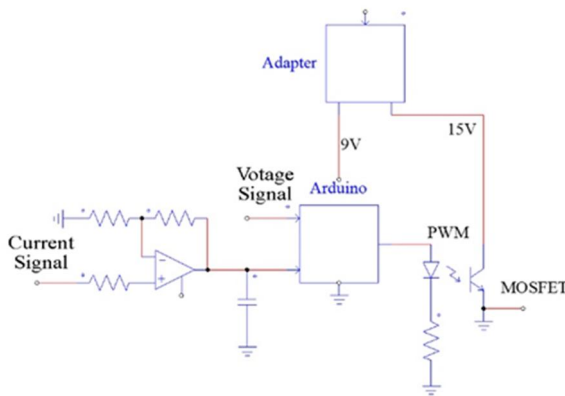

Figure 17. Diagram of controlling circuit

Table 2. Component parameters of the designed circuit

Components	Parameters
<b>Dynamic circuit</b>	
Input conductor $C_{in}$	220 $\mu$ F - 100V
Output conductor $C_o$	22 $\mu$ F - 400V
Coil L	250mH - 8A
Electric lock	IRF250 - 200V, 30A
Diode	SR5200 - 200V, 5A
<b>Controlling circuit</b>	
Microprocessor	Arduino Uno
Opto to excite MOSFET	TLP250
Opto amp	LM324
IC source	7809 (9V), 7815 (15V)

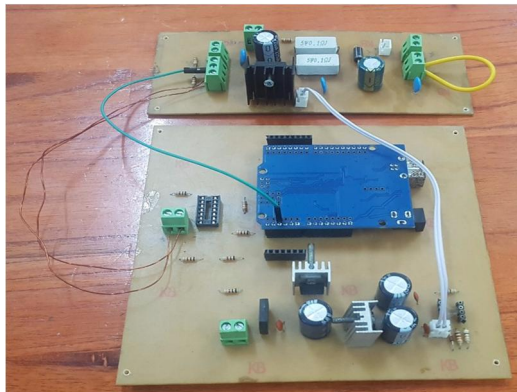

Figure 18. Prototype circuit

### 3.4. Experiment results

The properties of the proposed algorithm are tested on a solar PV cell simulator consisting of 5 solar PV panels connecting in series. Due to the limitation in the construction capacity, the experimental model in the paper is only able to meet 400W capacity. Therefore, each panel in the series is installed at the capacity of 58W. The tested loads are 4 incandescent bulbs at the capacity of 200W at 220V

The paper has conducted the experiment of tracking the maximum power points under different shading

conditions and studied the energy efficiency obtained from the system. Similar to the simulation, the real experiment is also based on two irradiance states with small difference in the irradiance (case 1) and large difference (case 2). The obtained results after completing the MPPT detection are shown in Figure 19, 20. The establishment time in both cases is similar (4s) and the establishment errors of each case is 0.4% and 0.7%, respectively.

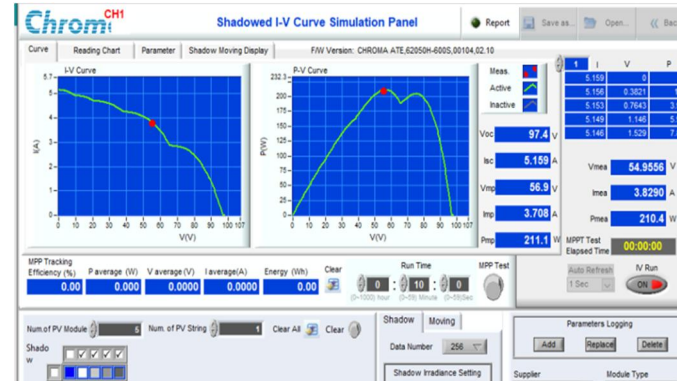

Figure 19. Identified working point in case 1

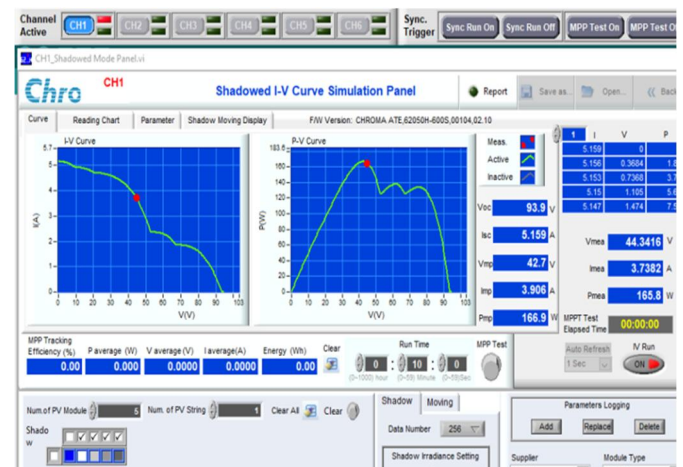

Figure 20. Identified working point in case 2

## 4. CONCLUSION

The paper has proposed a method of identifying and solving the partial shading problem in a solar PV panel configuration, in order to test a scheme to absorb the maximum solar irradiance to a solar PV panel to use in DC applications.

The paper has also proposed a method for determining the GPPs of a series of solar PV panels under partial shading conditions. The results of applying the proposed method which are presented through simulation and experiment have indicated the high feasibility for practical applications.

## REFERENCES

[1]. Kawamura H., Naka K., Yonekura N., Yamanaka S., Kawamura H., Ohno H., Naito K., 2018. *Simulation of I-V characteristics of a PV module with shaded PV cells*. Solar Energy Materials and Solar Cells, 75(3), 613-621.

- [2]. Mao M., Duan Q., Yang Z., Duan P., 2016. *Modeling and global MPPT for PV system under partial shading conditions using modified artificial fish swarm algorithm*. In Systems Engineering (ISSE), 2016 IEEE International Symposium on (pp. 1-7). IEEE.
- [3]. Gollop F. M., Roberts M. J., 2014. *Environmental regulations and productivity growth: The case of fossil-fueled electric power generation*. Journal of political Economy, 91(4), 654-674.
- [4]. International Energy Agency (IEA) Bioenergy, 2019. *Bioenergy: A Sustainable and Reliable Energy Source, Executive Summary*. prepared by the Energy Research Centre of the Netherlands (ECN), E4tech, Chalmers University of Technology and the Copernicus Institute of the University of Utrecht.
- [5]. Tsai H. L., Tu C. S., Su, Y. J., 2018. *Development of generalized photovoltaic model using MATLAB/SIMULINK*. In Proceedings of the world congress on Engineering and computer science (Vol. 2018, pp. 1-6).
- [6]. Park S. H., Cha G. R., Jung Y. C., Won C. Y., 2010. *Design and application for PV generation system using a soft-switching boost converter with SARC*. IEEE Transactions on Industrial Electronics, 57(2), 515-522.
- [7]. Patel H., Agarwal V., 2008. *MATLAB-based modeling to study the effects of partial shading on PV array characteristics*. IEEE transactions on energy conversion, 23(1), 302-310.
- [8]. Mäki A., Valkealahti S., 2012. *Power losses in long string and parallel-connected short strings of series-connected silicon-based photovoltaic modules due to partial shading conditions*. IEEE Transactions on Energy Conversion, 27(1), 173-183.
- [9]. Paraskevadaki E. V., Papathanassiou S. A., 2017. *Evaluation of MPP voltage and power of mc-Si PV modules in partial shading conditions*. IEEE Transactions on Energy Conversion, 26(3), 923-932.
- [10]. Ding K., Bian X., Liu H., Peng T., 2016. *A MATLAB-simulink-based PV module model and its application under conditions of nonuniform irradiance*. IEEE Transactions on Energy Conversion, 27(4), 864-872.
- [11]. Ji Y. H., Jung D. Y., Kim J. G., Kim J. H., Lee T. W., Won C. Y., 2018. *A real maximum power point tracking method for mismatching compensation in PV array under partially shaded conditions*. IEEE Transactions on power electronics, 26(4), 1001-1009.
- [12]. Koutroulis E., Blaabjerg F., 2012. *A new technique for tracking the global maximum power point of PV arrays operating under partial-shading conditions*. IEEE Journal of Photovoltaics, 2(2), 184-190.
- [13]. Spertino F., Akilimali J. S., 2009. *Are Manufacturing I-V Mismatch and Reverse Currents Key Factors in Large Photovoltaic Arrays?*. IEEE Transactions on Industrial Electronics, 56(11), 4520-4531.
- [14]. Mastromauro R. A., Liserre M., Dell'Aquila A., 2012. *Control issues in single-stage photovoltaic systems: MPPT, current and voltage control*. IEEE Transactions on Industrial Informatics, 8(2), 241-254.
- [15]. Mäki A., Valkealahti S., 2012. *Power losses in long string and parallel-connected short strings of series-connected silicon-based photovoltaic modules due to partial shading conditions*. IEEE Transactions on Energy Conversion, 27(1), 173-183.
- [16]. Molenbroek E., Waddington D. W., Emery K. A., 1991. *Hot spot susceptibility and testing of PV modules*. In Photovoltaic Specialists Conference, 2011., Conference Record of the Twenty Second IEEE (pp. 547-552). IEEE.
- [17]. Silvestre S., Boronat A., Chouder A., 2013. *Study of bypass diodes configuration on PV modules*. Applied Energy, 86(9), 1632-1640.
- [18]. Ishaque K., Salam Z., 2011. *A comprehensive MATLAB Simulink PV system simulator with partial shading capability based on two-diode model*. Solar Energy, 85(9), 2217-2227.
- [19]. Bidram A., Davoudi A., Balog R. S., 2012. *Control and circuit techniques to mitigate partial shading effects in photovoltaic arrays*. IEEE Journal of Photovoltaics, 2(4), 532-546.
- [20]. Ishaque K., Salam Z. 2018. *A review of maximum power point tracking techniques of PV system for uniform insolation and partial shading condition*. Renewable and Sustainable Energy Reviews, 19, 475-488.

---

#### THÔNG TIN TÁC GIẢ

**Nguyễn Đức Minh<sup>1</sup>, Đỗ Như Ý<sup>2</sup>, Trịnh Trọng Chương<sup>3</sup>**

<sup>1</sup>Viện Khoa học năng lượng, Viện Hàn lâm Khoa học và Công nghệ Việt Nam

<sup>2</sup>Trường Đại học Mở - Địa chất

<sup>3</sup>Trường Đại học Công nghiệp Hà Nội